

1	2	3	4	5	6
No.	Part Name	Drawing No	Material	Colour	Qty
1	Ferrule	FE.SCSM.S.1253-C08-C1-0-00	ZrO2	White	1
2	Flange	FL.SC.W135-0805-CU(SU)-00	Cu,Nickel plated(SU)		1

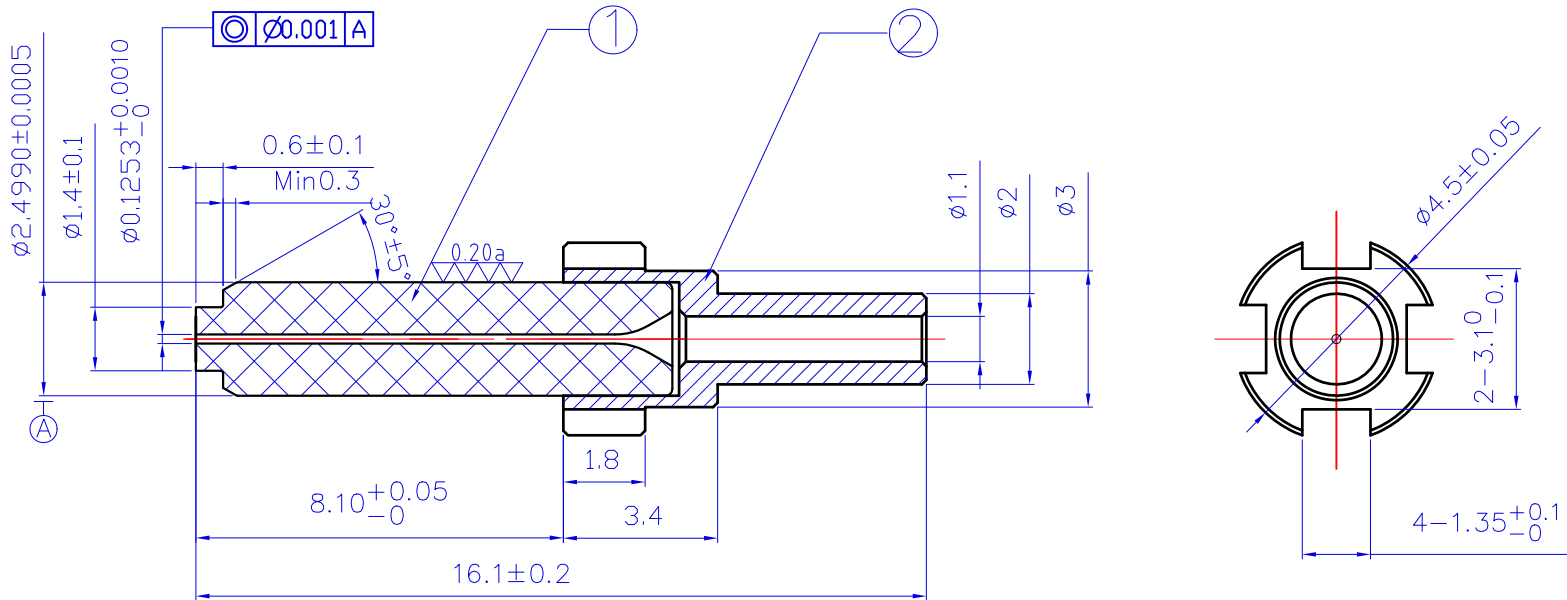

NOTE:

- 1、 REMOVE ALL BURRS AND BREAK SHARP EDGE
- 2、 NO DIRT ON SURFACE
- 3、 TOLERANCES UNLESS OTHERWISE SPECIFIED: $\pm 0.1, \pm 5^\circ$
- 4、 PRODUCT MUST BE RoHS COMPLIANT

△			
△			
△			
NO.	DATE	NOTE	SIGN

Title	SC/SM/STEP/125.3/With flange			Material		Unit	mm
Dwg No.	FE.SCSM.S.1253-C08-C1-CU(SU)-00			Treatment		Scale	6:1
Drawn	Yixue.Gan	Date	May.5 2019			Ver.	2.0
Checked	Andrew.Li	Date	May.5 2019				
Approved		Date					

T&S Communications Co.,Ltd.